

Wood Fire Installation & Owner's Operation Manual

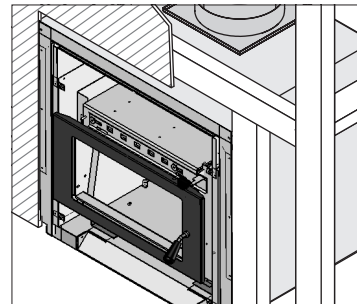
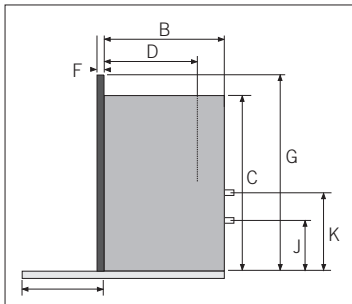

metrofires

Mega Smart Built-In

Installation Important information	Page 2	Where to install a Metro in your home...	Page 12
Preparing the wall/opening cavity	Page 3	Getting to know your Metro.....	Page 12
Installing the Mega Smart Built-In.....	Page 5	Operating your Metro	Page 12
Installing the ECO Built-In flue kit	Page 6	Cleaning and maintenance	Page 13
Floor protector requirements	Page 8	Replacement parts	Page 14
Fitting the fascia.....	Page 10	Troubleshooting	Page 15
Operation Important information.....	Page 11	Metro warranty.....	Page 16

WARNING! Important Information

• **WE HIGHLY RECOMMEND YOU READ THIS ENTIRE MANUAL AS INCORRECT OPERATION, MISUSE AND/OR LACK OF MAINTENANCE WILL VOID THE WARRANTY**

- The appliance and flue-system shall be installed in accordance with AS/NZS 2918 and the appropriate requirements of the relevant building code or codes
- Any modification of the appliance that has not been approved in writing by the testing authority is considered to be in breach of the approval granted for compliance with AS/NZS4013 and will void the warranty
- The appliance must be installed correctly. We recommend a competent and suitably qualified NZHHA installer

This Metro wood fire has been tested to and complies with AS/NZS 2918:2001 when installed in accordance with this manual. Please ensure you are fully conversant with this relevant standard and the contents of this manual. Correct installation is critical to the safe operation and performance of this wood fire.

CAUTION! Important Information

We recommend a Metro ECO Built-In flue system due to its extended 4.0m length of 150mm diameter flue pipe. The flue pipe is to be fully encased with a 200mm diameter inner casing and a 250mm diameter outer casing.

CAUTION! Important Information

- Mixing of appliance or flue-system components from different sources or modifying the dimensional specification or components may result in hazardous conditions. Where such action is considered, the manufacturer should be consulted in the first instance
- Do not install a Metro fire if there is any sign of visible damage to the product
- This appliance must be regularly maintained
- Use authorised Metro replacement parts only. The use of unauthorised parts may void the warranty
- This manual must be left with the home owner

Please take particular note of the following:

- All flue joints must be sealed and riveted; the bottom of the flue in particular **MUST** be fully sealed into the flue spigot of the Metro wood fire and bolted through the hole in the spigot.
- In New Zealand, the Metro fire must be bolted securely to the floor to comply with the seismic restraint provisions of AS/NZS 2918:2001.
- The Metro fascia is coated in gloss black vitreous enamel. Take care during assembly and when lifting or fitting the fascia that you do not damage this coating. Do not lift the Metro fascia with your fingers under the louvres.

Unpacking and familiarisation

The function of the Metro Mega Smart Built-In is to enable the fire to be installed into a timber framed wall replacing a masonry chimney at a fraction of the cost.

1. Installation must be strictly in accordance with this manual to comply with the test approvals to AS/NZS 2918:2001 held by Pioneer Manufacturing Ltd.
2. Certain points in this manual are critical to the safe operation of the Mega Smart Built-In. These points are highlighted with a '**WARNING**' or '**CAUTION**' heading and detailed within a black or grey panel.
3. There must be a minimum clearance of 30mm between the cabinet top and the underside of the timber lintel.
4. Please also refer to Stage 4 in relation to the Floor Protector requirements prior to commencing installation.

The Metro Mega Smart Built In

Having read the four critical bullet points above, unpack and familiarise yourself with the various components of the Metro Mega Smart Built-In.

Supplied with the Metro Mega Smart Built-In:

- 1 x 200mm/250mm diameter liner spigot
- 1 x airslide
- 1 x bag of assembly screws, bolts and nuts
- 1 x installation manual
- 2 x fire bricks

Not supplied BUT REQUIRED:

- 2 x Restraint fixtures (masonry anchors or wood screws)
- 1 x Metro ECO Built-In flue system
- 1 x Mega Smart fascia

Stage 1 - Construction and preparation of the wall opening/cavity

⚠ WARNING! Important Information

- Access is required to fit the flue spigot adaptor to the Mega Smart firebox and for installation of the ECO Built-In flue kit. Pioneer Manufacturing recommend lining the walls of the enclosure after the Mega Smart and flue kit have been installed.
- As the Mega Smart is built into an enclosure, the enclosure must be vented using one of the options detailed on page 4.

Construction of the timber framed enclosure

1. Frame up the enclosure to specification. Combustible framing materials are acceptable but a fire resistant wall board is required for the fascia to sit against such as 9mm Promina board or equivalent.

Framed cavity internal dimensions

Internal width	925mm +/- 5mm
Depth including wall lining	675mm +/- 5mm
Height to underside of lintel	855mm +/- 5mm

Wall lining opening dimensions

Height	818mm +/- 1mm
Width	925mm +/- 5mm
Flue centreline	445mm

**Please note: If a brick front is to be built you will need to allow for the thickness of the bricks.*

Make sure the floor where the fire will sit is level and flat as any discrepancies will make it difficult to slide the fire into place and align the fascia correctly. Also be precise when cutting the opening as the fascia will only cover the top of the opening by 7 or 8mm.

Please ensure you maintain the minimum air gaps between the Mega Smart cabinet and combustible material inside the cavity as below:

	Top	Sides	Rear
Air Gap	30mm	27mm	39mm

2. For an 'elevated' installation we recommend you fix additional framing beneath both sides and mount runners of the VZCC to support the installation. You will also require additional framing to fix the wall lining below the VZCC. The VZCC box can sit directly on the framing but we recommend fitting a floor to provide seismic fixing points for the VZCC. Insulation is not required under the VZCC.

For elevated installations, the floor protector may be installed after the wood fire is in position as it does not extend into the enclosure. However, the floor protectors rear edge must butt up against the non-combustible wall lining below the heater, and the joint at that point must be sealed to prevent the possibility of ember penetration.

3. A 1200mm x 1200mm sheet of 9mm Promina board or equivalent non-combustible material is required around the fascia as illustrated in Diagram 1.

It is usually convenient to carry the same lining material right up to the ceiling level. The side lining of the enclosure may be standard gib board or any other wall lining material.

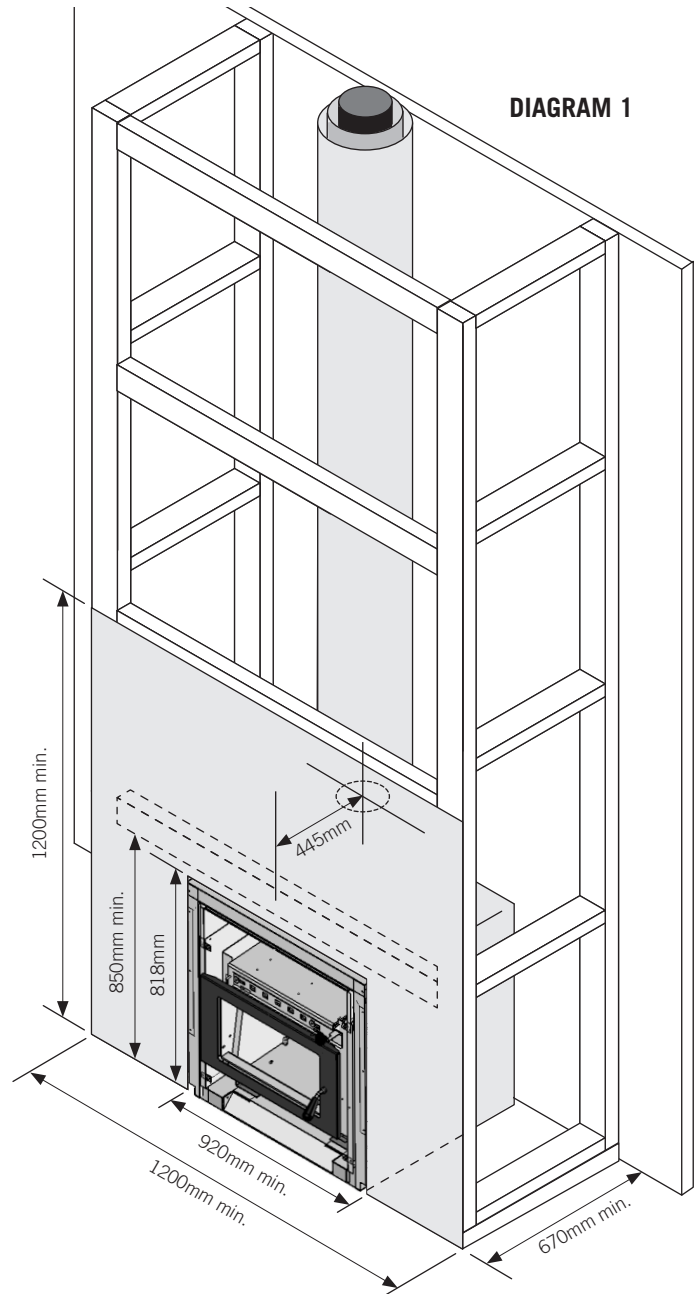

⚠ WARNING! Important Information

RECOMMENDED WALL LINING IS 9mm PROMINA BOARD OR EQUIVALENT NON-COMBUSTIBLE MATERIAL. PLEASE CONTACT THE RELEVANT MANUFACTURER FOR PRODUCT SPECIFICATIONS IF YOU CHOOSE TO USE A PRODUCT OTHER THAN PROMINA BOARD. FIRE RATED GIB BOARD IS NOT AN ACCEPTABLE MATERIAL TO USE AS AN EQUIVALENT.

Please note: Wall surfaces directly above the fascia may reach high temperatures, so materials such as wallpaper and water based paint may be adversely affected. For durability of finishes and surfaces you should contact the relevant manufacturers for their specifications. Pioneer Manufacturing Limited accepts no responsibility for the deterioration of surfaces of finishes.

Stage 1 - Construction and preparation of the wall opening/cavity

⚠ CAUTION! Important Information

AS THE MEGA SMART IS BUILT INTO AN ENCLOSURE, THE ENCLOSURE MUST BE VENTED USING ONE OF THE FOLLOWING OPTIONS.

- A. VENTING THROUGH THE CEILING SPACE OF THE HOME.
- B. VENTING THROUGH THE CAVITY WALL.
- C. VENTING THROUGH AN ECO OPTION KIT.

Cavity venting requirements

As the Mega Smart Built-In is built into an enclosure, the enclosure must be vented using one of the three options detailed below.

Venting through an external wall will require suitable precautions to prevent rodents and debris from entering or restricting the air vents. If grilles are used, the minimum vent area must be maintained through the grille itself. It is the responsibility of the installer to ensure the requirements of New Zealand Building Code Clause E2 (External Moisture) are complied with.

(A) Venting through the ceiling space of the home

The enclosure is constructed to the full height of the room and is fully open/vented into the ceiling cavity of the home.

(B) Venting through the rear wall of the cavity

A minimum open unrestricted vent area of 32,000mm² is required to cool the outer cabinet and flue liners within the combustible structure. This vent can be positioned in the rear wall or floor of the cavity, but venting through external cladding will need to be vermin proof and increased in size to ensure the minimum unrestricted open area as specified.

(C) Venting through the ECO Option Kit

Venting through the top of the enclosure using the 'ECO Option Kit' with the Metro ECO Built-In flue kit. If you choose to vent the enclosure with this method there must be no internal ceiling or 2nd storey floor blocking airflow within the cavity. The cavity must be fully open vertically from the outer cabinet to the enclosure capping/flashing plate as indicated in Diagram 2 below (Venting through the ECO Option Kit). Please see Diagram 5 for the ECO Option Kit installation.

DIAGRAM 2

Cavity venting

- (A)** Venting through the ceiling
 - (B)** Venting through the cavity
 - (C)** Venting through the ECO Option Kit
-
- 1** Built-In appliance
 - 2** Built-In flue kit
 - 3** Flue system air outlet

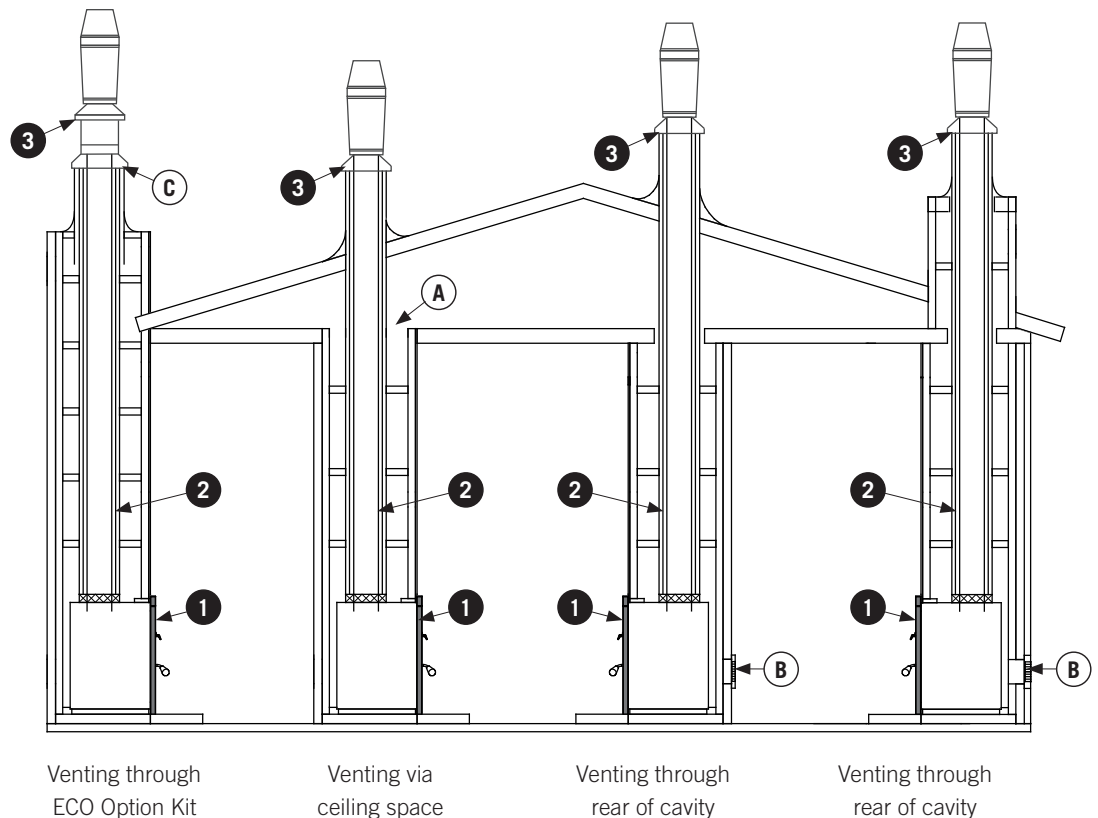

* All other clearances and installation criteria to meet AS/NZS 2918:2001.

Stage 2 – Installation of the Mega Smart Built-In

CAUTION! Important Information

It is critical for the safe and efficient operation of the Metro Mega Smart Built-In, that the front edge of the outer cabinet **MUST BE FLUSH** with the front edge of the wall lining. Frequently at time of installation the wall lining may not be complete, so if 9mm promina board is being used to cover the framing, the installer will need to have the front edge of the base panel 9mm forward of the framing.

Similarly if a brick facade is being constructed, the installer must move the VZCC forward so the front edge of the base panel ends up flush with the front face of the bricks once constructed.

If you are fitting the water heater to the Mega Smart built-in, please refer to the installation instructions included with the water heater. The Mega Smart booster is designed to fit externally to the firebox on either side and is best fitted prior to installing the fire into the enclosure.

Installing the Mega Smart Built-In firebox

1. Remove from within the firebox the plastic bag containing the component kit, two firebricks wrapped in cardboard and the top baffle assembly.
2. Position the Mega Smart Built-In into the wall opening you have created. Slide the Mega Smart Built-In into place and check it is central by ensuring the clearance between each side of the outer cabinet and the sides of the opening are equal. The front edge of the Mega Smart Built-In outer cabinet **MUST BE FLUSH** with the front face of the wall lining (Refer Diagram 3).
3. Secure the Mega Smart Built-In to the floor through the two restraint holes provided in each corner at the front of the cabinet. Masonry anchors are required for a concrete floor and wood screws for a timber or particle board floor.

Note: The Mega Smart Built-In must be secured rigidly to meet the seismic restraint requirements of AS/NZS 2918:2001

4. Using a 10mm spanner, remove the two bolts holding the air slide spacers which are located at the top, front of the firebox, ensuring the control arm of the air slide is located on the right side of the firebox. Attach the air slide to the firebox using the two bolts and spacers.
5. Position the 200mm/250mm diameter liner spigot into the top of the cabinet centralising it with the centre of the flue spigot. Secure the liner spigot into position using the 12 self tapping screws supplied.
6. Unwrap the two firebricks from the cardboard wrapper and fit the side bricks to each side of the firebox.

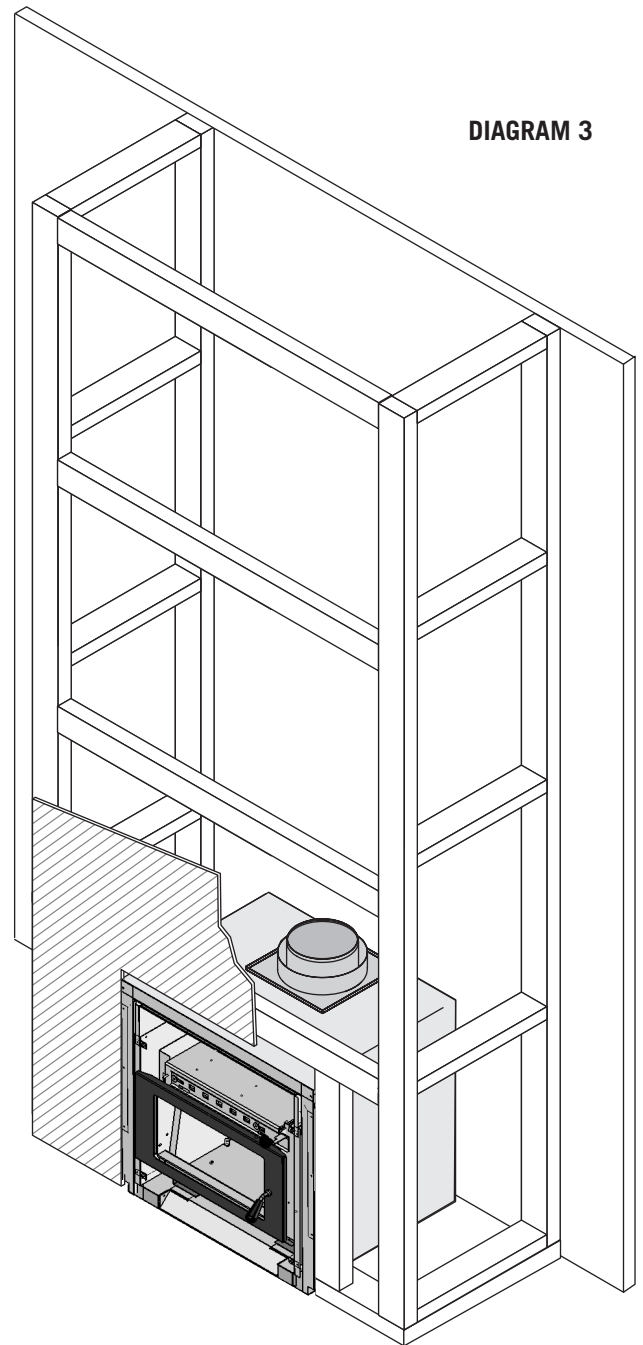

Stage 3 - Installation of the Metro ECO Built-In flue kit

CAUTION! Important Information

- As detailed within AS/NZS 2918:2001, it is not allowed to mix flue systems or components from different suppliers or manufacturers. The spigot adaptor supplied with the Metro Mega Smart is Metro flue system components designed to mate up with the Metro ECO Built-in flue kit. Only the Metro ECO Built-In Flue Kit can be used for installation with the Metro Mega Smart Built-In wood fire.
- The top of the flue must terminate a minimum of 4.6 metres above the top of the floor protector, the 'active' 150mm diameter stainless steel flue pipe must be fully encased with both 200mm and 250mm diameter flue liners/casings over its entire length, and the flue system and its installation must comply with AS/NZS 2918:2001. Additional flue system installation criteria is detailed below.
- As the flue system is to be enclosed in a structure replicating a conventional masonry chimney, the base of the weather cowl must be a minimum of 250mm above the top of the false chimney. (Refer Diagrams 4 & 5)

ECO Built-In flue kit assembly and installation

The Metro ECO Built-In flue kit is comprised of 3x Metro ECO Extension Kits and a Metro ECO Cowl. Each extension kit includes a 1200mm length of 150mm flue pipe, 200mm and 250mm inner and outer liners required for this installation.

- Penetrate the roofing material on the flue centerline. Cut roof cladding to the same diameter as the outer liner and bend up edges to create both moisture stop and clearance.
- Nog around the flue liner allowing a 25mm clearance. If you're installing the $\varnothing 300$ mm ECO Option Kit liner, this can be directly fixed to the timber framing at four points as shown in Diagram 5.
- Secure the flue pipes together and ensure the flue seams are staggered. The flue pipe sections must be fixed together at each joint with at least three monel or stainless steel fasteners, and the crimped ends of the flue inner and outer casings go to the top. The joints of the flue pipes must be sealed with Pioneer fire cement. Prior to installing the assembled flue pipe into the chimney cavity, take careful note to ensure there are no overhead power lines in close proximity.
- Lower the assembled flue pipe with the crimped end fitting into the flue spigot of the firebox. With the flue pipe in position and sealed with Pioneer fire cement into the flue stub, pilot drill through the hole provided in the front of the flue stub into the stainless steel flue pipe and secure with the M6 bolt and nut supplied in the plastic bag with the Insert model firebox.
- Lower the inner casing and engage it with the 200mm diameter inner liner spigot, repeat this step with the outer casing and engage it with the 250mm diameter outer casing spigot of the VZCC.
- When the flue system is in its final position, the top of the outer casing must be above the ridge line or roof as indicated in Diagram 6, as per AS/NZS 2918:2001.
- While still on the ground, assemble the ECO Cowl as follows;

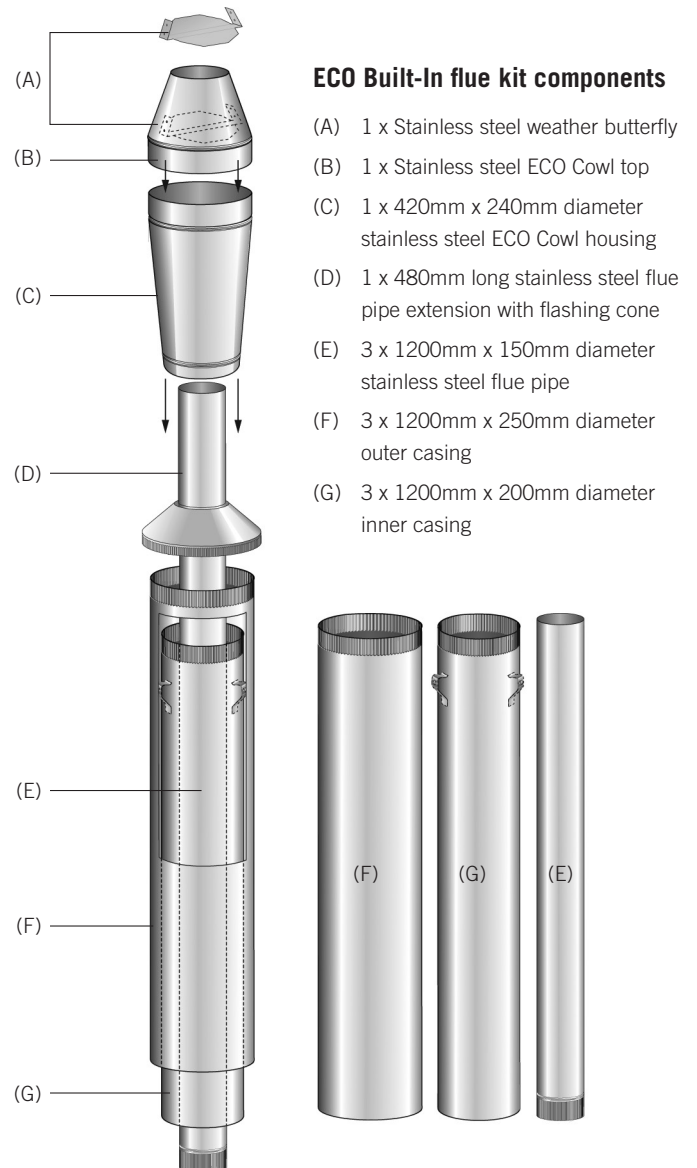

ECO Built-In flue kit components

- (A) 1 x Stainless steel weather butterfly
- (B) 1 x Stainless steel ECO Cowl top
- (C) 1 x 420mm x 240mm diameter stainless steel ECO Cowl housing
- (D) 1 x 480mm long stainless steel flue pipe extension with flashing cone
- (E) 3 x 1200mm x 150mm diameter stainless steel flue pipe
- (F) 3 x 1200mm x 250mm diameter outer casing
- (G) 3 x 1200mm x 200mm diameter inner casing

- Take the stainless steel weather butterfly (A) so the angled sections are facing up. With both arms and angled sections of the stainless steel weather butterfly (A) facing up, fit it into the stainless steel ECO Cowl top (B), and secure in position through the holes provided with stainless steel rivets.

Please note: Once fitted the weather butterfly will be slightly angled within the cowl housing.

- Fit the ECO Cowl top (B) into the ECO Cowl housing (C). Push both sections together until the swage ring on (B) rests completely on the open end of the cowl housing (C). Drill through the two pre-punched holes in the ECO Cowl housing and secure these two sections together with stainless steel rivets.

The removable section of the ECO Cowl is now fully assembled.

- Making your way back onto the roof, ensure the outer casing (F) is 'level' (+ or -10mm) with the top of the 150mm stainless steel flue pipe. Using a suitable flashing, weather proof the joint where the 250mm diameter outer casing penetrates the roof. Ensure the flashing used is compatible with the roofing material, and if fitting instructions are supplied with the flashing, these must be adhered to.

Stage 3 - Installation of the Metro ECO Built-In flue kit

9. Fit the 480mm long flue pipe extension/flashing cone (D), with the flashing cone at the bottom, fit its short flue section inside the top of the already installed 150mm diameter flue pipe. Ensure the three brackets extended below the flashing cone fit 'outside' the outer 250mm casing. Drill through the pre-punched hole in all three brackets into the outer casing and secure with rivets.
10. Taking the removable section of the ECO Cowl, position it over the top of the stainless steel flue pipe extension, and slide it down fully. This removable section does not require riveting and enables easy removal for future flue cleaning.

Flue termination methods

Assess the following aspects to determine the upper flue termination. These methods can be used on either sloping roofs or false chimney chases. Where the fire cabinet / flue liners cannot be vented from the ceiling cavity or other means, an additional venting liner can be installed on any termination design similar to that in Diagram 5.

Option 1 - ECO Built-In flue kit without air supply vent (Diagram 4)

Nog out framing to achieve a square aperture measuring 300mm internally to allow a 25mm clearance around the outer liner. A non-combustible capping is desirable with compatible weather flashing.

DIAGRAM 4

250mm minimum

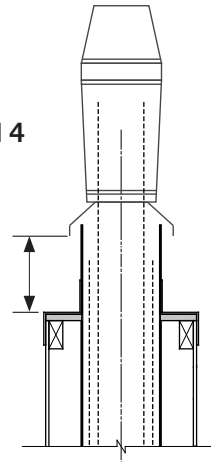
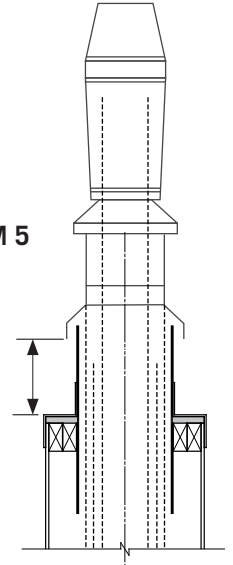

DIAGRAM 5

250mm minimum



Option 2 - ECO Built-In flue kit with additional air supply vent (Diagram 5)

Nog out framing to achieve a square aperture measuring 300mm internally. The $\varnothing 300$ mm ECO Option Kit liner can touch timber in four points for direct fixing into the timber framing. A non-combustible capping is desirable with compatible weather flashing.

Flue System Minimum Heights (In compliance with AS/NZS 2918:2001)

The Metro ECO Built-In flue kit complies with AS/NZS 2918:2001 and its 4.6m height requirement (4.6m minimum from the top of the floor protector to the top of the flue pipe).

If the flue centerline is within 3m from the ridge, the outer casing must end at least 600mm above the ridge. If it is further than 3m from the ridge, the outer casing must extend at least 1000mm above the point of roof penetration.

However as external structures and the proximity of other buildings will differ for every installation, some situations will require additional flue height to comply with the standard. Refer to Diagram 6 below. (All measurements in mm).

Note: AS/NZS2918:2001 Section 4, details flue system installation requirements in full.

DIAGRAM 6

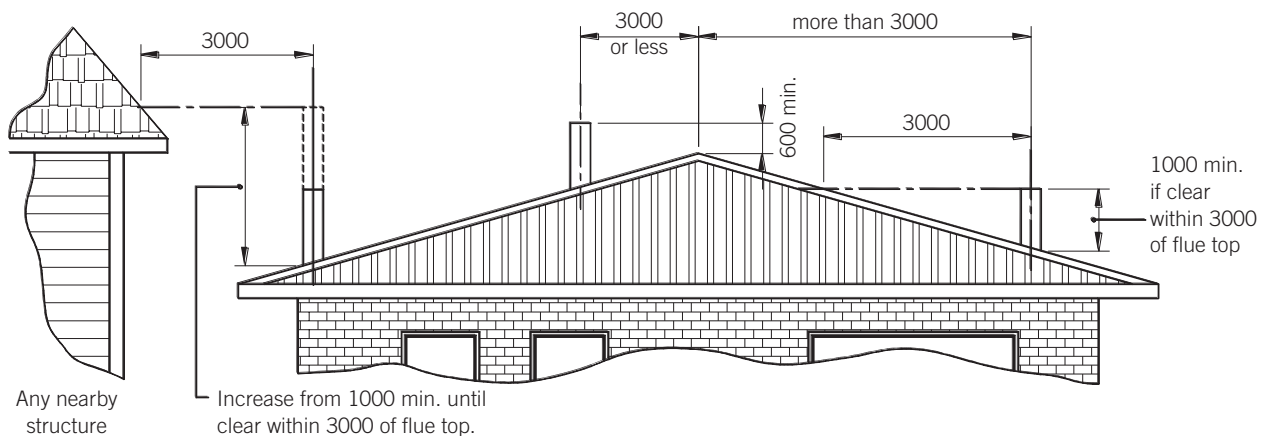

Stage 4 – Construction and installation of the floor protector (hearth)

CAUTION! Important Information

If the Mega Smart Built-In is to have a raised floor protector, the base on which the Mega Smart Built-In firebox will be installed needs to be raised to the same height. (See diagrams opposite)

Pay particular attention to making sure the floor where the fire will sit is level and flat as any discrepancies will make it difficult to slide the fire into place and to align the fascia correctly.

Combustible Floor (Insulated Floor Protector)

All installations of the Metro Mega Smart Built-In require an insulated floor protector that complies with AS/NZS 2918:2001 and this installation manual. This Floor Protector must be a minimum width of 1057mm and a minimum overall depth of 505mm.

Minimum overall depth is the distance from the front of the wall lining (behind the fascia) to the front point of the Floor Protectors non-combustible surface. The Floor Protector must have an insulating rating which is equal to or greater than 26mm thick Eterpan LD. Recommended construction of tiles on 26mm thick Eterpan LD board or equivalent.

Non-combustible floor (Ash Floor Protector)

All installations of the Mega Smart Built-In onto a concrete or non combustible floor structure only require an ash hearth floor protector that complies with AS/NZS 2918:2001 and this installation manual. (See Diagrams 9 & 10 opposite).

If the floor structure in front of the installation is non combustible (e.g. concrete) the floor protector may be omitted. However, if heat sensitive floor coverings (e.g. carpet) are fitted it is still necessary to keep these clear from the appliance to the minimum distances specified in the table below.

In this case, if tiles or similar are required for decorative purposes, they can be fixed directly to the concrete floor. This will make the top of the floor protector approximately flush with the floor covering. The tiled area must project out a minimum of 505mm from the front of the wall lining (behind the fascia) and must be a minimum width of 1057mm.

Please note: You will need to raise the Mega Smart Built-In firebox by the same amount as the thickness of the tiles fixed to the concrete floor. (see Diagram 10)

For elevated installations, the floor protector may be installed after the wood fire is in position as it does not extend into the enclosure. However, the floor protectors rear edge must butt up against the non-combustible wall lining below the heater, and the joint at that point must be sealed to prevent the possibility of ember penetration.

Floor protector construction

Model	Built-In installation Combustible floor	Built-In installation Non combustible floor	Minimum width	Minimum projection
Mega Smart Built-In	Insulated floor protector	Ash hearth floor protector	1057mm	505mm
Insulating - recommended construction of tiles on 26mm thick Eterpan LD board or equivalent.				

	Depth	Height	Width
Fascia	30mm	822mm	1057mm

	Depth	Height	Width
Firebox	631mm	814mm	860mm

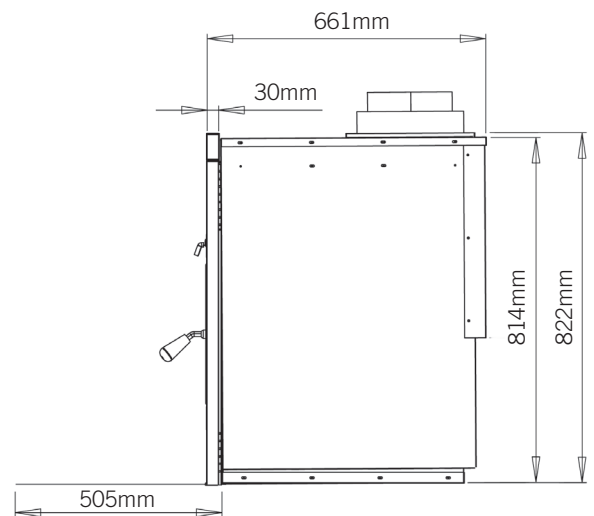

Stage 4 – Construction and installation of the floor protector (hearth)

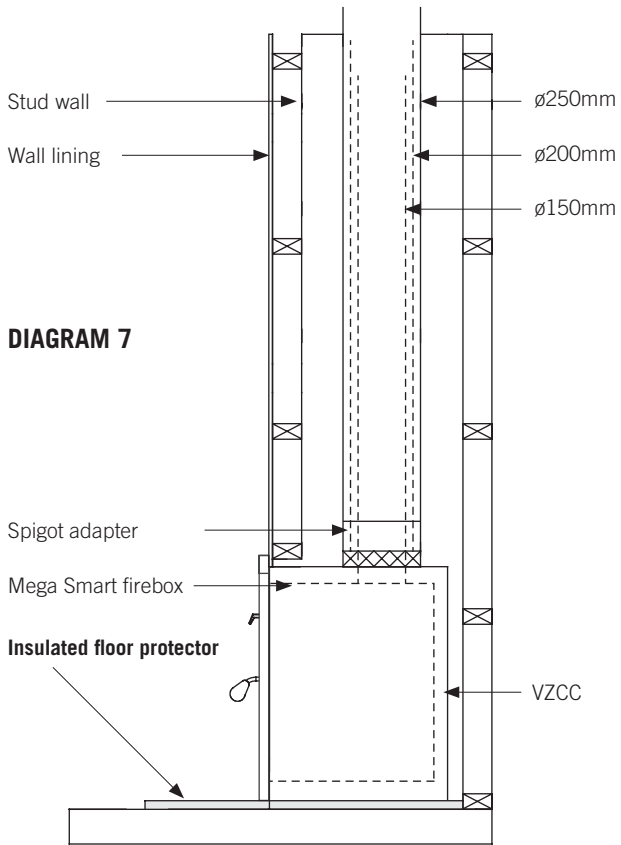

DIAGRAM 7

ALL FLOORING TYPES

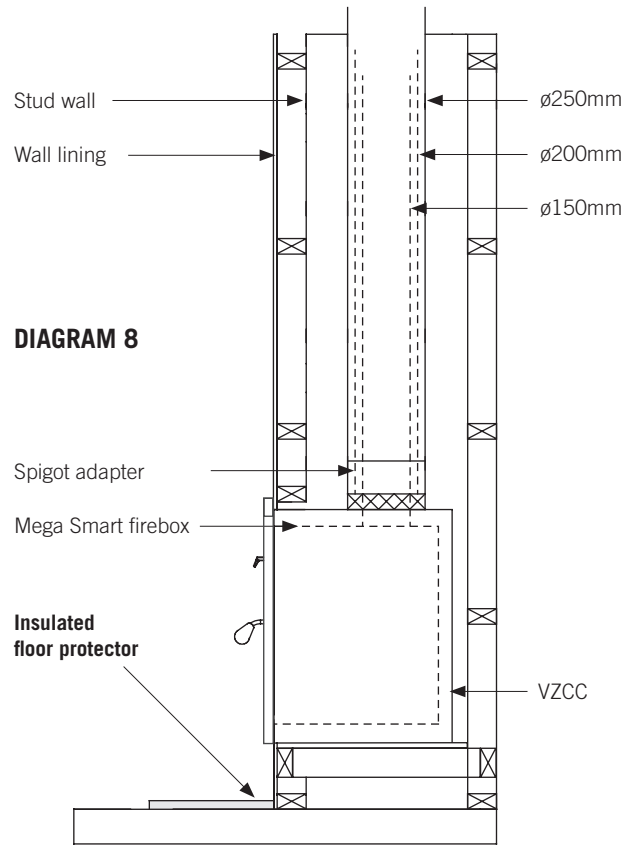

DIAGRAM 8

ALL FLOORING TYPES (ELEVATED INSTALL)

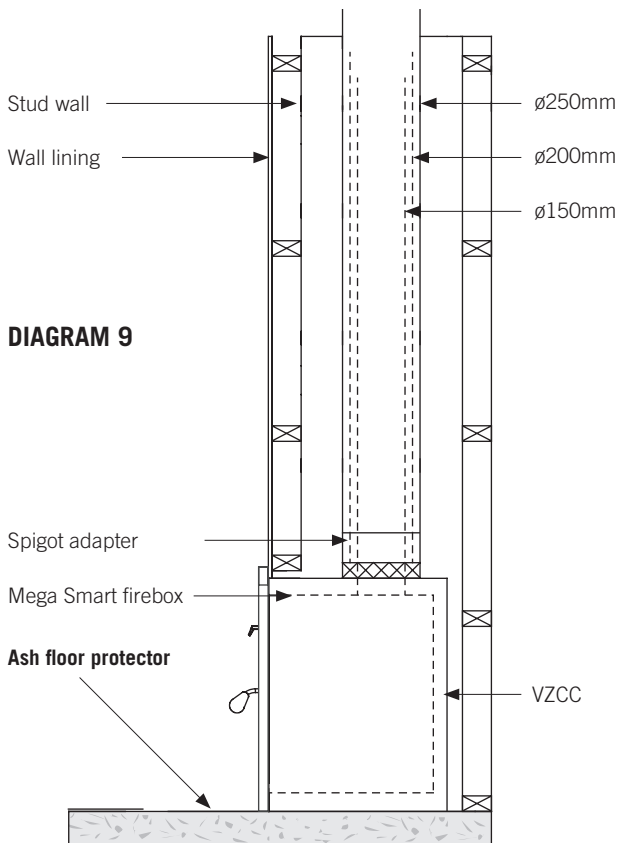

DIAGRAM 9

NON COMBUSTIBLE FLOOR ONLY

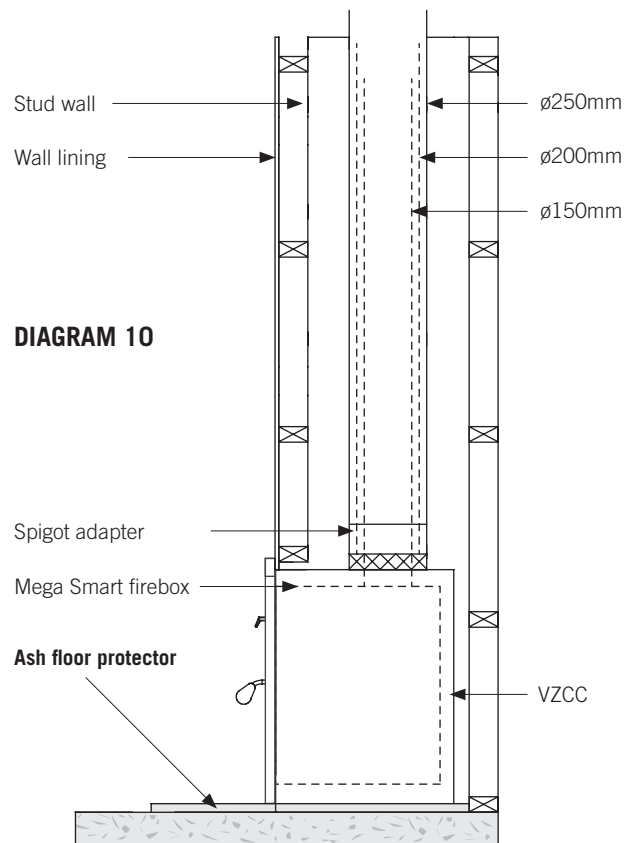

DIAGRAM 10

NON COMBUSTIBLE FLOOR ONLY

Stage 5 – Fitting the Mega Smart Built-In fascia

On a flat surface (a floor) open the fascia carton and remove the door. Taking the door in both hands, with the spindle end in your right hand and the outer face of the door facing you, attach the door to the firebox as follows;

1. With the door in a 45 degrees open position, allow the lower hinge pin on the bottom left hand side of the firebox to pass into the hole provided in the bottom of the door frame.
2. Lift the door until the top of the door frame passes over the top of the hinge pin, align the hole provided on the top face of the door frame and lower it down over the top hinge pin.
3. Take the door handle from the plastic bag and screw it onto the door spindle by turning it clockwise.
4. To fit the fascia, ensure the four speed clips provided are positioned over the large diameter mounting holes in the four tabs located in the front of the cabinet (fascia mount points).
5. Attach the fascia with the four longer screws that are supplied in the plastic bag, taking care that the air control lever passes through the slot provided in the fascia. Centralise and level the fascia on the fire box insert door and secure the four screws.

The fascia should be evenly spaced around the door frame and sit evenly against the wall lining when the firebox cabinet has been correctly positioned. (The door can still be removed from the fire with the fascia in place when it is correctly fitted).

6. The air control knob can now be fitted.

Mantel clearance

A timber or combustible mantel must not project more than 150mm from the finished wall lining and there must be a minimum distance of 500mm above the top of the Mega Smart Built-In fascia to the underside of the mantel. If the clearance is less than the minimum specified, a heat shield will be required to be fitted under the mantelshelf in accordance with AS/NZS 2918:2001.

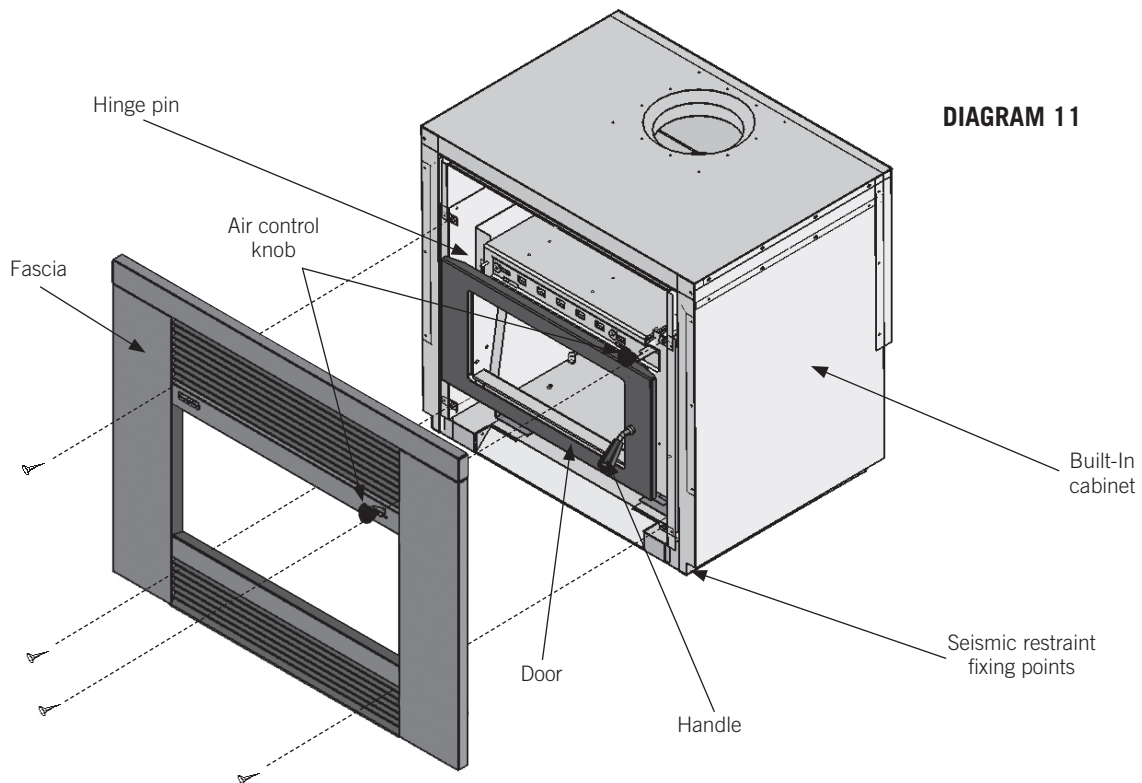
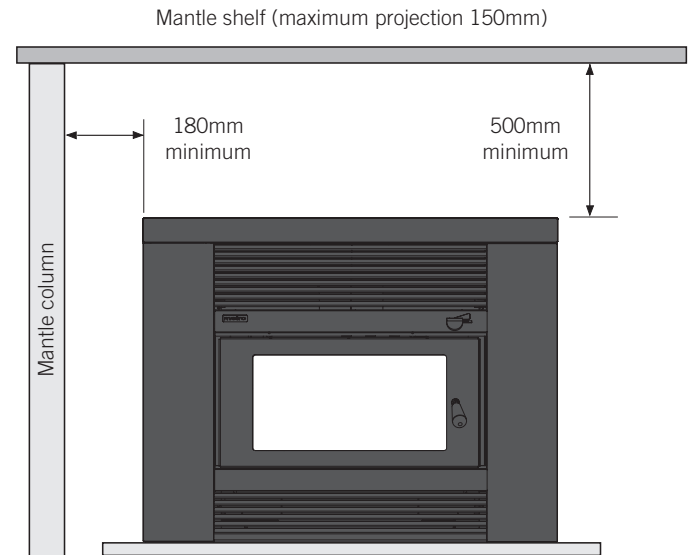

DIAGRAM 11

WARNING! Important Information

• **WE HIGHLY RECOMMEND YOU READ THIS ENTIRE MANUAL AS INCORRECT OPERATION, MISUSE AND/OR LACK OF MAINTENANCE WILL VOID THE WARRANTY**

- Any modification of the appliance that has not been approved in writing by the testing authority is considered as breaching AS/NZS 4013 and will void the warranty
- Do not use flammable liquids or aerosols in the vicinity of this appliance when it is operating
- Never operate your Metro with the top grill removed
- Do not dry clothes on or near this appliance
- Do not use flammable liquids or aerosols to start or rekindle the fire OR store fuel within the Metro's specified installation clearances
- Never operate your Metro with the door ajar, except on initial start up
- Open the air control fully before opening the Metro's door.

CAUTION! Important Information

- This appliance should be maintained & operated at all times in accordance with this instruction manual
- This appliance should not be operated with cracked door glass, over worn, faulty or missing door seals
- Do not use driftwood, treated or unseasoned (wet) fuel, the use of most types of preservative treated wood as fuel can be hazardous and will damage your appliance
- Burning unseasoned (wet) fuel or incorrect operation on extended low burn cycles will cause excessive creosote to form. Creosote is very corrosive and excessive buildups will result in the flue pipe, flue spigot and upper burn chamber failing. Failure of the appliance and/or flue system due to creosote damage is not covered under warranty. The formation of such is not an appliance issue it is a fuel and operational issue
- This appliance must be regularly maintained and replacement parts must be authorised Metro parts only
- Do not empty ash into a combustible container.

Congratulations on the purchase of your Metro wood fire

This low emission, slow combustion appliance is designed to give you many years of warmth and service, subject to the following key factors. These key factors, if not adhered to are the major causes of unsafe installation, poor performance and flue blockages and potential product failure.

1. Your Metro wood fire must be installed correctly. Metro recommend a competent and suitably qualified NZHHA installer.
2. The only fuel to be used in this appliance shall be wood that meets the following criteria.
 - Less than 25% moisture content
 - Has not been treated with preservatives or impregnated with chemicals or glue,
 - Is not chipboard, particle board, or laminated board,
 - Is not painted, stained or oiled
 - Is not driftwood or other salt impregnated wood
3. The appliance shall be operated at all times in accordance with the "Installation and Operating Instructions" supplied with each appliance.
4. It is preferable that Metro wood fires should be installed with a Metro ECO Flue System.
5. Coal must not be used as a fuel.

Please also note the following important points:

- In New Zealand a building consent is required from your local building authority. The homeowner is responsible for obtaining this consent
- As correct installation is critical to the performance and safe operation of your Metro, it is recommended your Metro be installed by a NZHHA registered installer or a person suitably qualified in the installation of wood fires. Your Metro retailer will be able to arrange professional installation for you
- During the very first fire your Metro will give off an odour and fumes as the firebox paint cures. Do not be alarmed; open all windows and externally opening doors in that room and close any internally opening doors. This curing process will last for approximately one hour and is likely to happen this one time

- Properly seasoned (dry) timber is necessary for the Metro to operate efficiently; firewood that contains a high moisture content will result in flue pipe blockages, reduce heat output and create other issues.

Note: Once split, Softwood usually takes 12 months to season - Hardwood can take up to 24 months to season - Wood must be stored in a location that enables air circulation. Unseasoned wood stored in a closed woodshed without air circulation will still be unseasoned 12 months later.

- It is critical that the fire not be operated with over worn, faulty or missing door seals. Door seals will harden over time and become over-worn (3-4 year's) this will cause air to leak into the fire, causing the appliance to 'over fire'
- It is critical that the fire not be operated with over worn, faulty or missing bricks, baffle plate, promet extension (white board on the baffle plate)
- It is critical that the fire not be operated with cracked or broken door glass.

Please note, the above 3 points require regular inspection/maintenance (every time the ash bed is cleaned out, generally 3-5 times a season) and if not maintained will void the firebox warranty. A glowing firebox or lower fluepipe is just one sign you are over firing your appliance. Please ensure you keep your proof of purchase/receipt on any parts you purchase.

- For optimum performance fuel must be loaded so the logs lay "front to rear" in preference to laying across the width of the firebox. Spaces should be left between the logs to enable oxygen to get to as much of the surface of the fuel as possible
- A small hot fire loaded frequently is more efficient than a large fire burning on a low setting
- Your Metro is covered by a full unconditional 12 month warranty on replacement parts, and a 10 year firebox warranty.

Where to install a Metro wood fire in your home

Wood fires are usually installed in the main living area, which is the section of the home that is usually kept the warmest, being the area in the home most frequently occupied. However, before deciding on the best location for your Metro wood fire you may wish to consider:

- Water heating. If you are intending to have a wetback it is important that the wood fire is as close as practically possible to the water storage cylinder
- Split level homes are best heated when the wood fire is installed on the lower level, as the heated air will rise to the higher levels
- Building construction is another consideration. Specified clearances from walls, curtains etc must be maintained and you need to ensure no structural beams or internal gutters etc are directly above your preferred site. If you have a two storey dwelling you need to consider the second storey to ensure you don't have the flue directly outside a second storey window.

Generally, you can install your Metro in your home anywhere that suits you; Pioneer offer various fan systems to transfer heat to other sections of the home that are not heated sufficiently. It is necessary if using a fan system that the Metro you have purchased has sufficient output to heat the total area you wish to heat. Your Metro retailer or installer will be able to advise if you are uncertain.

Getting to know your Metro wood fire

Operating your Metro fire is simple and you will quickly learn how to get the best from it. First take a minute to familiarise yourself with your new Metro.

- Raise the door handle anticlockwise until the latch releases, then slowly pull the door open. Load fuel and then close the door ensuring the latch is secure. Never operate with the door open or not latched securely, except on start up – see below.
- There is a single air control making your Metro fire easy to adjust. This control moves from left to right, which is 'low to high'.

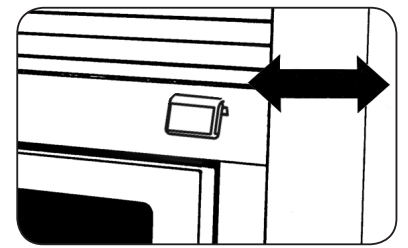

Mega Smart Built-In air control

Operating your Metro wood fire

If your Metro has only been installed within the past few days, the fire cement seal at the base of the flue will not be fully cured. To ensure the cement sets without blistering it is recommended you burn 2-3 sheets of loosely crumpled newspaper at a time, approximately once every hour over a 6-8 hour period.

During the very first fire your Metro will give off an odour and fumes as the firebox paint cures. Do not be alarmed. Open all windows and externally opening doors in that room and close any internally opening doors. This curing process will last for approximately one hour and is likely to happen this one time.

Start up

Place a quantity of loosely crumpled newspaper on the base of the firebox until it is approximately half full of paper, or place firelighters on the base of the firebox. Add dry kindling and move the air control knob fully to the right, being the 'full open' position.

Light the paper at two or three locations across the front of the door opening and leave the door slightly ajar resting on the latch pin if necessary for a few minutes while the fire establishes. Once the kindling is burning

well, open the door and add 2-3 small logs at a time until you have a well-established fire. Usually this will take approximately 30 minutes, during which time the air control should be set on "high" and the door should be closed, except for the initial few minutes and when fuel is being added.

Normal operation

Once the fire is well established, regulate the air control to achieve the desired burn rate and heat output. As you move the air control to the right, burn rate, firebox temperature and heat output will increase, if you move the control to the left they will decrease. Please note:

- Always open the air control fully prior to opening the door, then open the door slowly. Every time you refuel, leave the air control on 'high' for a minimum of 20-25 minutes
- When loading logs, place them end-on, 'front to back'; air spaces should be left between the logs to enable oxygen to get to as much of the surface of the fuel as possible
- Never use the door to force wood into the firebox, as this is likely to break the glass.

Cleaning and maintenance for your Metro wood fire

Your Metro fire will give you many years of efficient service with minimal maintenance if operated correctly using seasoned fuel. Your Metro fire must be regularly maintained and replacement parts must be authorised Metro fires parts only.

The Metro Mega Smart Built-In fascia is coated with vitreous enamel. Vitreous enamel is extremely durable and designed to last the life of the appliance. As vitreous enamel is glass, a solid or heavy object dropped or banged against a panel could chip the enamel surface.

All model Metro fires can be cleaned with a soft cloth when the appliance is not in operation.

Door glass

Providing your fuel is properly seasoned, under normal operating conditions the air-wash design of the Metro's firebox will keep the door glass clear. If the glass requires cleaning you may use either a razor blade scraper or crumpled wetted newspaper dipped in wood ash rubbed over the glass.

If your door glass breaks it must be replaced with 5mm thick ceramic glass which is available from your local Metro retailer.

Door seals

Over time, usually 3-4 years, the door and glass seals will become hard and cause air to leak into the firebox, causing the appliance to 'over fire'. Your Metro retailer stocks replacement woven fibreglass door and glass seals, which need replacing when they become hard and over worn.

The door of your Metro is easily removed. Hold it in both hands and lift the hinge end of the door up and over the top hinge pin, then lower the door from the bottom hinge pin.

Side bricks

Hair-line cracks are not uncommon and are a result of the intense heat within the Metro's firebox, coupled with mechanical damage caused by accidental impact when fuel is being loaded. However if the side bricks become cracked to the extent that they start to break up, they must be replaced.

Door adjustment

Provision is available on both sides of the door for adjustment.

To adjust the hinge end of the door, open the door fully, loosen the top hinge nut and slightly lift the latch end of the door; you will see the hinge assembly move back 1-2mm which will usually be sufficient. Retighten, then repeat by loosening the lower hinge nut, this time applying a slight downwards pressure onto the door to move the lower hinge assembly back a similar distance, then retighten.

The door latch is also adjustable, as the latch pin on the right side of the firebox is fitted through a slot which enables the latch pin to be loosened, moved back and re-tightened.

Ash removal

Over a period of time ash will build up in the base of the Metro's firebox and require removal. The time this build-up takes depends on the density and cleanliness of your fuel.

To remove the excess ash your Metro should not be operating.

- Open the door, and using a hearth shovel or similar, empty the excess ash directly into a steel or non-combustible container.
- If the ash is not disposed of immediately, be careful where you store it, as the ash can retain heat for many days and become a fire hazard.
- You must leave a bed of ash in the base of the firebox approximately 10mm deep; this insulates the base of the firebox and improves combustion.

Top baffle

This is a 'sacrificial' wear part of the firebox and should be checked monthly. Usually only the promet (white board) front/underneath section needs to be replaced when it starts to disintegrate.

Note: Cracks in the promet are not uncommon and have no adverse effect on the operation of your Metro. These cracks are the result of intense heat coupled with expansion and contraction. Burning wood which is not properly seasoned, i.e. 25% moisture content or more, will over time cause the promet to disintegrate and require replacement.

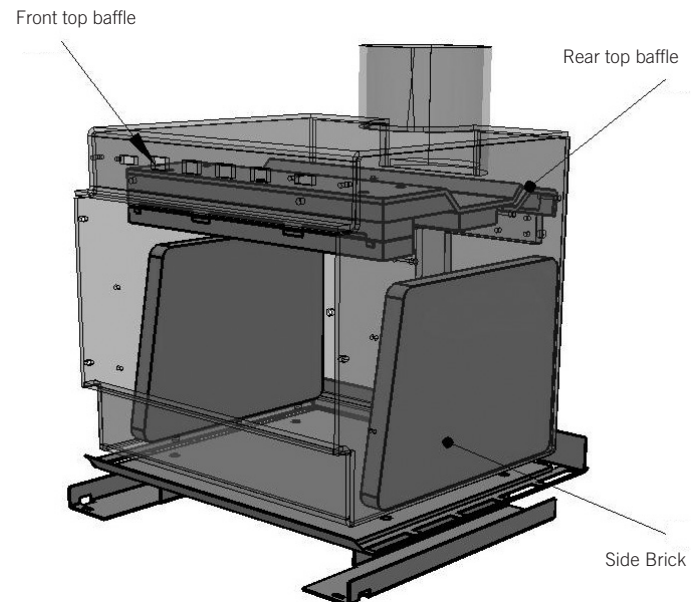

To remove and replace your Metro's top baffle, proceed as follows: -

- Open the Metro's door fully, reach inside with the palm of your hand face up and extended, lift the front baffle approximately 20mm, then lift it forward out through the door opening placing it on a sheet of newspaper you have placed on the front of the hearth. Now lift the rear baffle section up off its pins and remove out through the door opening.
- To refit the baffles. Proceed in the reverse order and note, the rear baffle must be fitted so its back-edge is touching the back of the firebox.

Cleaning and maintenance for your Metro wood fire

Flue systems

Should be checked annually, particularly the bottom end of the lower flue section at its rear lock formed joint. If deterioration is noticed contact your Metro retailer or installer.

The flue pipe should also be swept a minimum of once a year, or as required during the winter season. If smoke enters the room when you open the Metro's door this usually indicates the flue pipe is becoming restricted and needs cleaning. The frequency of flue pipe cleans depends on many factors, with the main variables being:

- The seasoning of the wood. If not properly seasoned you will require frequent flue pipe cleans.
- The density of the wood. Softwoods generally result in more deposits building up in the flue pipe.

To clean the flue pipe of your Metro, proceed as follows:-

- Open the Metro's door fully, reach inside with the palm of your hand face-up and extended, lift the top baffle approximately 20mm, then lift it forward out through the door opening, placing it on a sheet of newspaper you have placed on the front of the floor protector. To prevent jamming, removal and replacement of the top baffle is best performed using both hands.

Note: The Mega Smart Built-In features a two piece top baffle.

- Close the door and slide the air control to the left.
- Once on the roof, remove the cowl from the top of flue system and sweep the flue pipe using a 150mm-diameter flue pipe brush as detailed in the instructions provided with the fluebrush.
- Once the flue pipe is clear, clean and refit the cowl. Remove the excess soot which has fallen into the firebox, leaving a layer of ash 10mm deep on the base of the firebox, then refit the top baffle.

Note: The baffle must be fitted so its rear is touching the back of the firebox; if uncertain refer to the previous page 12 in the installation section of this manual, which shows an illustration of the baffle location.

Parts guide for your Metro – Baffle, promet and wetback

Listed below are the parts and product codes for your Metro wood fire. The promet/baffle should be regularly checked and must always be in place during the operation of your fire.

Note: Cracks in the promet are not uncommon and have no adverse effect on the operation of your Metro. These cracks are the result of intense heat coupled with expansion and contraction and is normal wear & tear.

Your Metro wood fire must be regularly maintained and we recommended it is also serviced annually. If a wood fire is not regularly maintained and serviced, the life span will be reduced. If your Metro wood fire has been neglected, by not being regularly maintained and serviced, with authorised Metro parts replaced as required, your warranty may be declined.

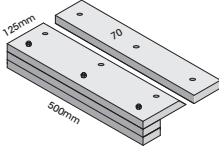
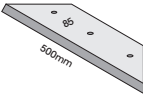
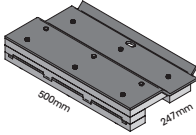
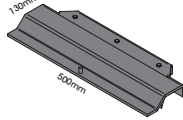
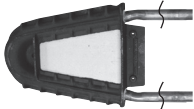
Model	Type of promet required / Type of steel baffle(s) required				Wetback options
• Mega Smart	<p>Mega Smart Front Promet 500-1895</p> 	<p>Mega Smart Rear Promet 500-1900</p> 	<p>Mega Smart Front Baffle 500-2450</p> 	<p>Mega Smart/Ambie Plus Rear Baffle 500-2500</p> 	<p>Mega Smart Booster 450-0400</p> 

Troubleshooting your Metro wood fire

If your Metro is installed correctly, your fuel is dry and you operate your fire correctly, you will find it to be a pleasure to use. Metro's many years of experience within the wood heating industry has shown that dissatisfaction is mainly due to:

- unseasoned fuel
- faulty installation
- operational error
- or a combination of the above 3 points.

Correct operation

Modern day wood fires need to be operated hard and fast, more so than low and lazy to ensure the firebox and flue pipe runs hot and efficiently. If the fire and flue pipe is up to temperature it will perform extremely well, the smoke will draw up the flue pipe with ease, and the fire will produce good amounts of heat.

If the fire is operated on low a lot of the time, the door glass will run black, the flue pipe will tend to block up more frequently and the fire will end up smoking into the room when reloading. It's better to have a small fire running hard and fast, rather than a big fire running low and lazy.

The following may be of assistance if you are experiencing any problems with the operation of your Metro Fire.

Smoke enters the room when the Metro's door is ajar

(possible reasons and solutions)

Check flue pipe joins

If the flue pipe joins are not sealed correctly, the flue pipe will not draw as well as it should. The flue pipe join connecting into the flue spigot on top of the Metro is most critical, if this is not sealed correctly, smoke will enter the room when the door is ajar. To check this join is sealed correctly, run a match or lighter flame around the join. If the flame is sucked into the spigot then it is not sealed correctly. This check needs to be done when the fire is not going. Ensure you check the rear of the flue pipe/spigot join, as due to the seam in the flue pipe, this is the most common area for not being sealed correctly.

Ensure the fuel you are using is correctly seasoned

If you are burning unseasoned fuel (wet), the fire will cause nothing but problems. The Metro won't deliver much heat, it will be lazy, smoke will enter the room when the door is ajar, and the door glass will run black. Unseasoned fuel is the main contributor to excessive creosote deposits which can be corrosive to your appliance and flue system.

Flue pipe length is too short

Add more flue pipe as the longer the flue system, the better the draw of the flue pipe. Please note, if you did not purchase the Metro ECO Flue System, you will not have the ECO Cowl which increases draw. We highly recommend the Metro ECO Cowl is fitted as this will increase the draw. If you already have an ECO Cowl and smoke is still entering the room, please add another 600mm length of flue pipe.

Downdraft/Turbulence blockage

If you have checked all of the previous factors and the fire is still smoking into the room, it's possible there may be a down draft issue. Down draft is environmental and can be caused by many variables, and it is purely trial and error to ascertain the cause.

Air turbulence and/or negative air pressure influences around the flue termination can be caused by too close or overhanging trees or natural/artificial ridges etc. Address these where possible or look to extend the flue above the roofline.

Other options may be:

- 'H' Cowl, designed purely for downdraft issues, but if you have an ECO Cowl fitted as standard, you will also need to add another 600mm of flue pipe to compensate as the H Cowl is shorter in length
- Directional Cowl, designed for high wind areas.

Air control setting

Ensure the air control setting is on high before opening the door to reload, as this increases the draw up the flue pipe. Open the door slowly.

If your Metro did not smoke, but its starting too and is getting worse:

The flue pipe is in need of a clean. It is recommended that the flue pipe be cleaned every season, however if you are burning the fire on low a lot, or are using unseasoned fuel, flue pipe cleans will be required more frequently.

Other issues you may experience

I can smell smoke in the room after a low burn cycle

The smell is creosote that will be seeping through the flue pipe join or out of the flue spigot onto an external surface, thus creating the smell in your room. The cause will be either unseasoned fuel, fuel mass too large, incorrect operation on low burn cycles or a combination. Creosote is very corrosive and excessive buildups will result in the flue pipe and potentially the flue spigot and upper burn chamber failing. The formation of excessive creosote is not an appliance issue, it is a fuel and operational issue. Failure of flue pipe or firebox due to creosote build up is not covered under warranty as excessive creosote build up is only possible from either unseasoned fuel or incorrect operation.

The Metro won't turn down as much as it did

The door itself may need readjusting, the hinge and latch is slotted and allows for movement. Loosening the hinge and moving it back a few mm will make the door seal tighter and stop air leaking into the fire. The door and glass seals may be in need of replacing, which is generally required every 3-4 years.

Familiarise yourself with the instructions on page 8 before proceeding with this maintenance.

Warranty details for your Metro wood fire

Metro wood fires are manufactured in New Zealand, using the highest quality of materials, workmanship and the latest manufacturing techniques, which is why we offer a full 10 year firebox warranty and a 1 year parts warranty for your peace of mind.

Metro Warranty

(NZ Consumer laws apply to this warranty)

Pioneer Manufacturing Limited (Pioneer) warrants the steel firebox against defective materials and workmanship which would render it unfit for normal domestic use, from the date of purchase by the original consumer, for a period of 10 years.

Components including panel coating, door retainers, door seals, glass, trim, baffle & bricks are warranted for a period of 1 year from the date of original purchase for normal domestic use against defective materials and workmanship.

All associated accessories including, but not limited to, fans, flue systems, flue shields, wetbacks, tool sets, ash pots etc, are covered by a 1 year warranty against defective materials and workmanship.

It is recommended, but not a condition of this warranty, that a full service/inspection of the Metro fire be carried out at the end of each winter season.

Warranty Conditions

- The Metro fire must be installed, operated and maintained strictly in accordance with the building code and this installation and operation manual
- The Metro fire must be installed and used in a domestic application
- This warranty covers appliance like for like replacement or repair at the manufacturer's discretion but excludes freight, travel, installation, labour and/or any other associated costs
- Pioneer or their agents are not liable for any loss or expense direct or indirect arising from the failure of any part or operation of the appliance
- Operation of this appliance in violation of the warnings in this operation and installation manual will void this warranty
- Your Metro fire must be regularly maintained and we recommended it is also serviced annually. Proof of servicing may be required. If a wood fire is not regularly maintained and serviced, the life span will be reduced. If your Metro wood fire has been neglected, by not being regularly maintained and serviced, warranty may be declined

CAUTION! Important Information

Note: The following 3 points require regular inspection/maintenance (every time the ash bed is cleaned out, generally 3-5 times a season) and if not maintained will void the firebox warranty. Please ensure you keep your proof of purchase/receipt on any parts you buy.

- It is critical the fire not be operated with over worn, faulty or missing door seals. Door seals will harden over time and become over-worn (3-4 year's) and will cause air to leak into the fire, causing the appliance to 'over fire'. Do not operate the fire with cracked, or broken door glass
- It is critical the fire not be operated with over worn, faulty or missing bricks, baffle plate or baffle extension (white board on or under the baffle plate)
- A claim under this warranty should be directed to the retailer who supplied the Metro fire. If this is not possible write directly to the manufacturer stating details of fault, model, serial number of your Metro, dated proof of purchase and name of retailer purchased from.

Warranty Exclusions

(This manufacturer's warranty does not cover)

- Service calls which are not related to any defect in the product (i.e. operational, installation or fuel issues). The cost of a service call will be charged if the problem is not found to be a product fault
- Defects caused by factors other than normal domestic use or use in accordance with the product's operation manual
- Defects caused through the product being operated in an 'over-fired' manner resulting in sections of the firebox operating excessively hot to the point that sections glow red. (Note – This will result in distortion of the firebox)
- Defects to the product caused by accident, neglect, misuse or act of God
- The cost of repairs carried out by non-authorized repairers or the cost of correcting such unauthorised repairs
- Required maintenance as set out in this manual.

Service under this manufacturer's warranty must be provided by a repairer authorised by Pioneer Manufacturing Ltd. Such service shall be provided during normal business hours.

IMPORTANT! Complete and retain these details at time of purchase:

Purchase Date

Serial Number

Model

Colour

Retailer

